

## 2-Way Diaphragm Valve, Forged stainless steel body, pneumatically operated

- Cavity free and self draining
- Hermetical separation of fluids from the operating mechanism by diaphragm
- Fully machined from SS 316L bar-stock– no welded components
- Fully Autoclavable
- Full traceability as per EN 10204 3.1 and ASME BPE
- Various internal surface finish available each with less than 0.40 Ra



Series 25 pneumatically operated diaphragm valve has a flow-optimized stainless steel body, a diaphragm, and actuator. The stainless steel body is available with various surface finish.

The diaphragm is both a switch as well as a sealing element for the media. It is easily replaceable.

An actuator is provided for the protection of diaphragm and for opening and closing actuation of valve.

This valve is designed for zero dead leg and can be mounted to be self-draining. This allows high flow capacity and variety of applications.

Technical Data	
<b>Connection Size</b>	½" - 3"
<b>Rated Air Pressure</b>	6 Bar(g)
<b>MOC – Wetted (Contact)</b>	Stainless Steel 316L
<b>MOC – Non-wetted (Non- contact)</b>	Polyamide or ASTM A351 CF8 (SS 304)
<b>Seal material</b>	EPDM, PTFE
<b>Media</b>	Neutral gases and liquids, high purity, sterile, aggressive or abrasive fluids
<b>Viscosity</b>	Up to viscous
<b>Surface finish</b>	Mechanical or Electro Polish
<b>Media temperature</b>	EPDM -10°C to +75 °C
	PTFE -10°C to +90 °C
<b>Ambient temperature</b>	Up to +90 °C
<b>Sterilization temperature</b>	EPDM Briefly up to +130 °C
	PTFE Briefly up to +150 °C
<b>End connections</b>	ASME BPE - EN ISO 1127/ISO 4200 and BS 4825 are available on request
• V-band (Hygienic) Clamp • Butt-Weld	
<b>Installation</b>	As required, preferably with handle in upright position
<b>Installation for Self-draining mounting</b>	Tilted 10° to 35° to the horizontal and inclined 3° to 5° to the direction of flow

2-Way diaphragm valve, forged stainless steel body, pneumatically operated

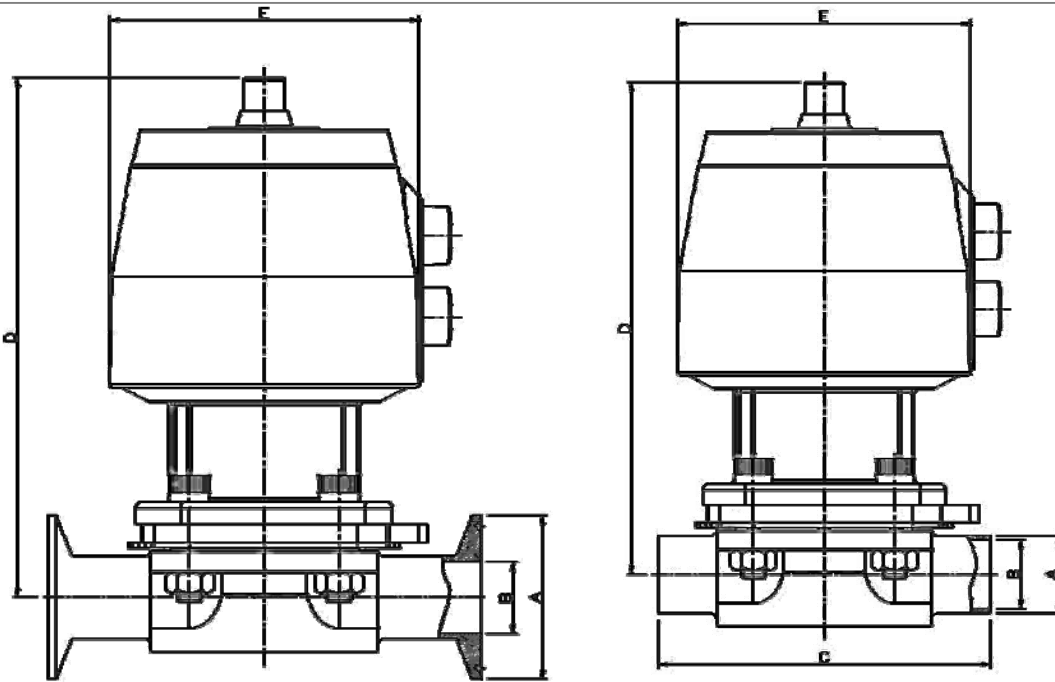

**Figure 251**  
Body with V-band (Hygienic) Clamp Connector

**Figure 252**  
Body with Butt-weld End

Dimensions for end connections according to ASME BPE connection type

Body with V-band (Hygienic) Clamp Connector (Refer Figure 251)					
Connection Size	Flange OD	Pipe ID	Face to Face Length	Max. Valve Height from Pipe Center	Outside Diameter of Actuator
	A	B	C	D	E
	(mm)	(mm)	(mm)	(mm)	(mm)
1/2" Mini	25.00	7.75	96.4	110.7	68.0
1/2" Regular	25.00	9.40	109.5	112.4	68.0
3/4"	25.00	15.75	121.4	144.7	96.4
1"	50.40	22.10	133.4	190.5	120.5
1 1/2"	50.40	34.80	156.5	225.3	150.6
2"	63.90	47.50	179.5	242.8	150.6
2 1/2"	77.40	60.20	179.5	276.9	180.0
3"	90.90	72.90	179.5	283.2	180.0

Body with Butt-weld End (Refer Figure 252)					
Connection Size	Pipe OD	Pipe ID	Face to Face Length	Max. Valve Height from Pipe Center	Outside Diameter of Actuator
	A	B	C	D	E
	(mm)	(mm)	(mm)	(mm)	(mm)
1/2" Mini	12.70	7.75	71.0	110.7	68.0
1/2" Regular	12.70	9.40	84.0	112.4	68.0
3/4"	19.05	15.75	96.0	144.7	96.4
1"	25.40	22.10	108.0	190.5	120.5
1 1/2"	38.10	34.80	130.9	225.3	150.6
2"	50.80	47.50	154.1	242.8	150.6
2 1/2"	63.50	60.20	154.0	276.9	180.0
3"	76.20	72.90	154.0	283.2	180.0

Notes:

1. For V-band (Hygienic) clamp connections, clamp connector will be welded to the valve body with butt-weld end. Internal finish will be provided as per customer's request.
2. Dimensions and tolerances for end connection and face-to-face length are as per ASME BPE.
3. All other dimensions are approximate and subject to change without prior notice.

Ordering Chart

**ORDER IDENTIFICATION NUMBER**

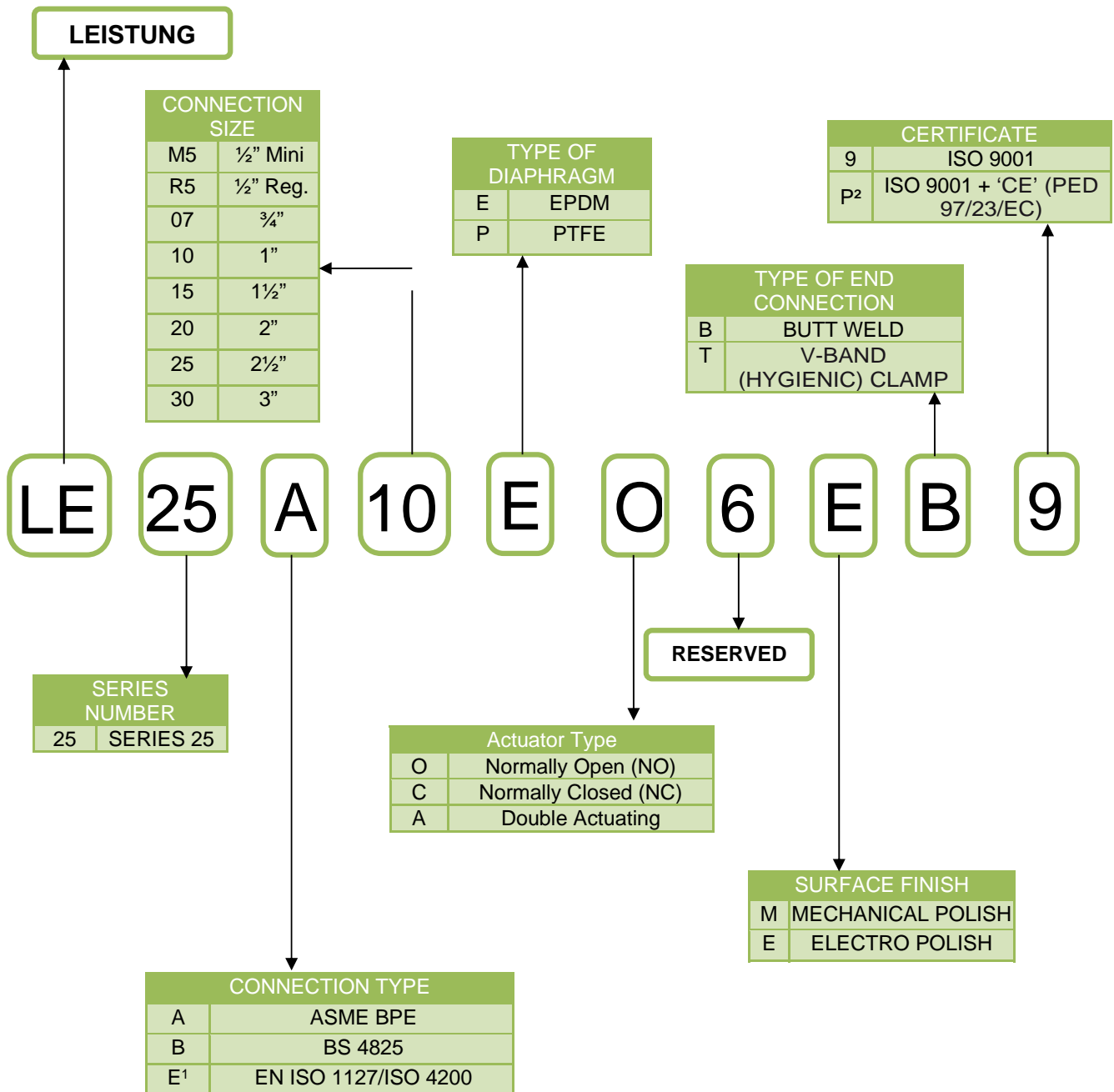

Note:

- 1 – EN ISO 1127/ISO 4200 offers standards for butt-weld end connections only.
- 2 – 'CE'-marking is applicable for valves with connection sizes 1½", 2", 2½" and 3" only.
- 3 – Valves with end connection sizes according to EN ISO 1127/ISO 4200 and BS 4825 are available on request.

In case of special application conditions, please e-mail at: [rnd@leistung.in](mailto:rnd@leistung.in)  
 The technical specifications are subject to change without notice.