

## Auto Cleaning Filtration System With Disc Type Cleaner

- Elimination or reduction in requirement of bag or cartridge filters in downstream
- Reduction in operator handling, inventory costs and landfill waste
- Reduction in product loss, more thorough automatic contaminant purge
- Reduction or elimination of operator intervention for safer operation
- Virtually maintenance free, near 100% uptime
- Compact design, lower capital cost, can fit most installations
- Stainless steel screens available up to minimum 50 micron slots to handle a wide range of filtration needs
- Long operating life of cleaning actuators with twin cylinder design comprising bridged system
- Completely flameproof design available with option of logical pneumatic controller



Leistung's auto cleaning filtration systems have a filter housing, a strainer element, a self-cleaning mechanism, supports and required accessories.

The filter housing contains a wedge wire strainer element. Unfiltered fluid enters through inlet. Solids are deposited on the interior surface of the filtration screen of the strainer element and filtered fluid exits at the outlet. When the media requires cleaning (based on time set with fully automatic control or selected manually with semi-automatic control), a spring loaded cleaning disc (wiper) travels down and up, wiping the media clean of concentrated solids in both strokes. Once the debris are removed from the slotted screen, the cleaning disc directs the contaminant to the bottom of the housing and out of the flow path. This cleaning process happens while the filter remains in service, thereby maintaining process efficiency and reducing loss of valuable product.

An on/off switch and a speed controller are provided to control the operation of wiper when filter is ordered with fully automatic operation control. Additional feature such as timer based operation and automatic purging are also available.

Technical Data	
<b>Flow Rate</b>	Up to 40 m <sup>3</sup> /hr
<b>MOC</b>	SS – 304, 316, 316L
<b>Pressure Rating</b>	1 – 5 bar, more on request
<b>Temperature Rating</b>	-25°C to +65°C, more on request
<b>Connection Size</b>	1½" – 3"
<b>Connections</b>	Flange, Socket
<b>Vessel Closure</b>	Eye Bolt
<b>Sealing Material</b>	Silicon
<b>Vessel Support</b>	Legs / Flexible Tripod
<b>Surface Finish</b>	Matt Finish, Blast Finish
<b>Customized Design</b>	Available in customized design to accommodate specific requirements
<b>Accessories (Optional)</b>	Pressure Gauge, Vent Valve, Drain Valve, D.P. Gauge

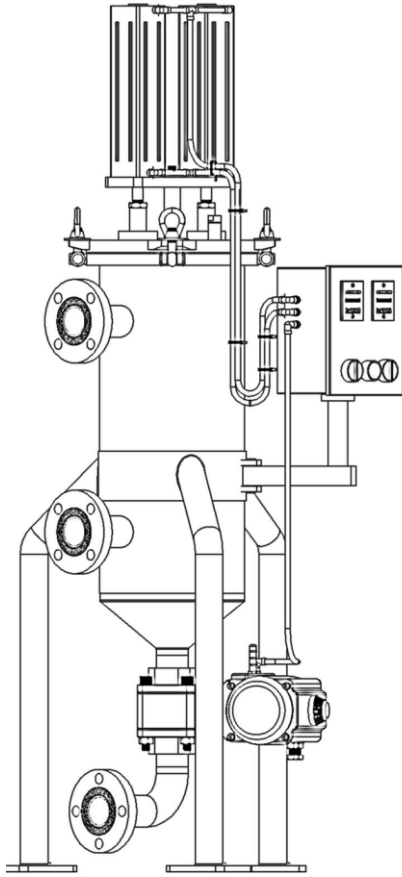

With Logical Pneumatic Controller

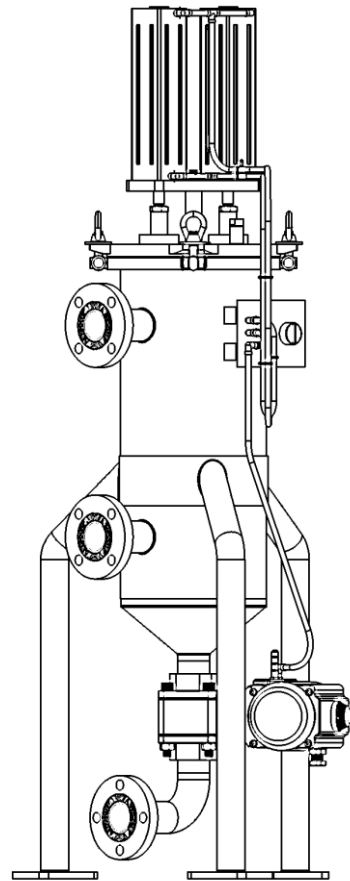

With Logical Electric Controller

### Ordering Chart

#### ORDER IDENTIFICATION NUMBER

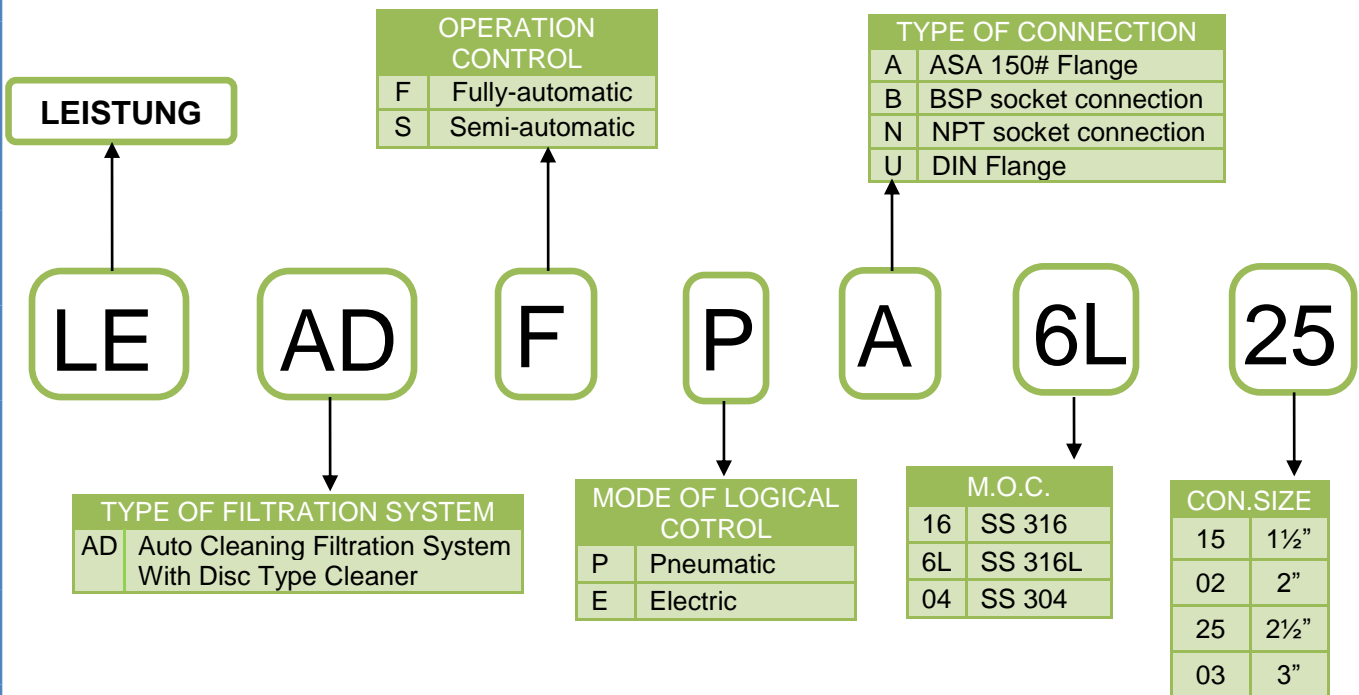

In case of special application conditions, please e-mail at: [rnd@leistung.in](mailto:rnd@leistung.in)  
 The technical specifications are subject to change without notice.